



Visit our homepage  
for additional support  
[parker.com/pmde](http://parker.com/pmde)

Bulletin MSG30-3255-INST/UK

# Installation and Start-Up Manual

## PQDXXA-Z10

### Electronic Module for p/Q-Control of PVplus

Firmware: PQDXXA-Z10-r08 and higher

Effective: February, 2023  
Supersedes: September, 2022



ENGINEERING YOUR SUCCESS.

**Setup Manual for digital pump control module PQDXXA-Z10 to operate electro hydraulic proportional controls for PVplus.**

<b>Contents</b>	<b>Page</b>
<b>1. Introduction</b> .....	3
Dimensions .....	3
Ordering Codes .....	3
Name plates .....	4
Block diagram .....	5
Features: .....	5
Technical Data .....	6
Signal flow chart .....	7
Control loop quality .....	7
<b>2. Security advice</b> .....	8
Symbols .....	8
Name plates, markings .....	8
Work with electronics .....	8
<b>3. Important notes</b> .....	8
Intended usage .....	8
General instructions .....	8
Liability .....	8
Storage .....	8
<b>4. Mounting / Installation</b> .....	8
Scope of Supply .....	8
Mounting .....	8
Installation and removal of module from the rail .....	9
Operating limits .....	9
Electrical Connection .....	9
Electrical Interfacing .....	9
Wiring diagram .....	10
Digital Inputs .....	11
Enable p/Q-control .....	11
Enable ramp .....	11
Analog Inputs .....	11
Displacement command signal input .....	11
Pressure command signal input .....	12
Horse power command signal input .....	12
Sensor signals .....	13
Analog Outputs .....	17
Digital outputs .....	17
<b>5. Programming</b> .....	19
<b>6. Operating Parameters</b> .....	21
6.1 MODE – Standard (STD) .....	21
6.2 MODE – EXPERT (EXP) .....	22
6.3 MODE – Offline (PARKER EXP) .....	32
6.4 PID Parameter Setting .....	35
6.5. Important settings and diagnosis values .....	37
<b>7. Connecting diagram for proportional displacement control; code ...FPV</b> .....	38
<b>8. Connecting diagram for p/Q-control; (all versions)</b> .....	40
<b>9. Trouble shooting guide</b> .....	42

**1. Introduction**  
**Dimensions**

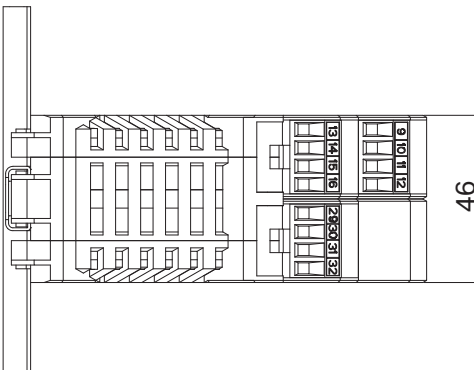
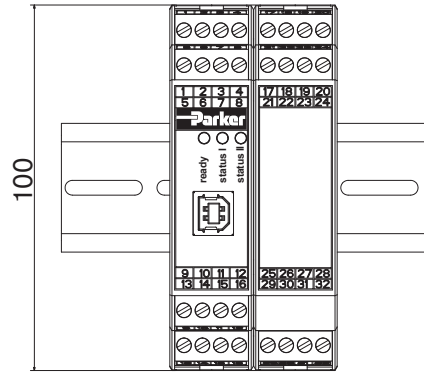
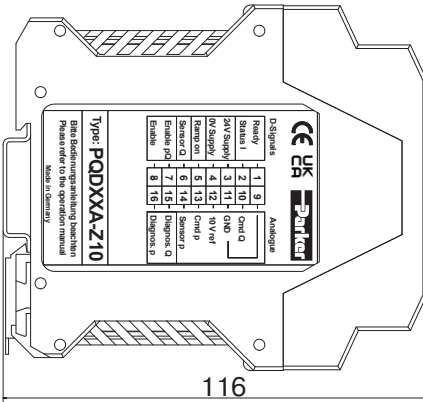

**Ordering Codes**

**PQDXXA-Z10**

Digital Control module with USB-B Port for PV-plus pumps.



**PQDXXA-ZXX-Kabel**



Programming cable to connect the control module **PQDXXA-Z10** to a Computer via a USB Interface (USB-A at the computer / USB-B at the module).

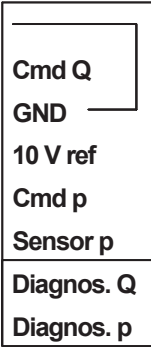

A new programming cable is needed since module generation Z10 (not in the delivery content of the module).

**Name plates**

 			
<b>D-Signals</b>		<b>Analogue</b>	
Ready	1	9	
Status I	2	10	
24V Supply	3	11	
0V Supply	4	12	
Ramp on	5	13	
Sensor Q	6	14	
Enable pQ	7	15	
Enable	8	16	
<p><b>Type: PQDXXA-Z10</b></p> <p>Bitte Bedienungsanleitung beachten          Please refer to the operation manual</p> <p>Made in Germany</p>			

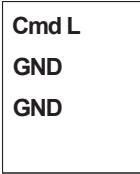
 			
<b>Amplifier</b>		<b>Analogue</b>	
sol. p	17	25	
sol. Q:A	18	26	
sol. p	19	27	
sol. Q:A	20	28	
sol. Q:B	21	29	
24V Supply	22	30	
sol. Q:B	23	31	
0V Supply	24	32	
<p><b>Type: PQDXXA-Z10</b></p> <p><b>F00/ABCDE/RXX</b></p>			
Date Code	Serial number	Software revision	

**Block diagram**

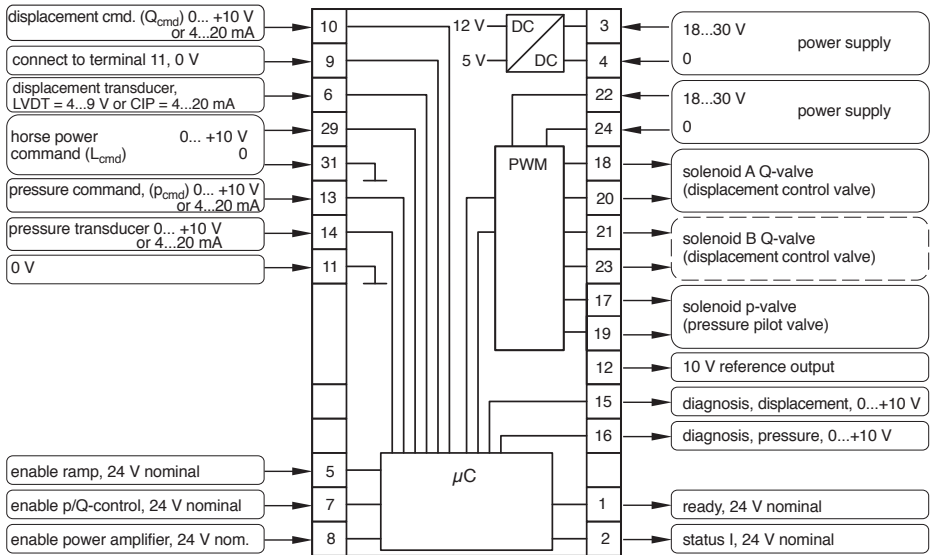

Parker digital control module series **PQDXXA-Z10** for snap track mounting is compact, quickly installed and easy to connect with plug-in PIN blocks. The digital concept offers perfect reproducibility and optimized adaption to all PVplus

pump displacements and all possible functions from a simple displacement control to a closed loop pressure control with horse power limitation through an easy to use setup software.

**Features:**

- Digital control circuit
- Adjustable control circuits for pump displacement and pressure
- Constant solenoid current control
- Analog input commands (optional current and voltage)
- Diagnosis output for displacement and pressure (if pressure transducer installed)
- Individual adjustable ramp function for displacement and pressure
- Enable input for solenoid power amplifier stage
- Status monitor
- Parameter setting via data cable with USB Interface
- Electrical connection via plug-in PIN blocks
- Compatible to the relevant European EMC specifications
- Easy to use PC based setup software
- Covers all pump displacements from 16 to 360 cm<sup>3</sup>/rev
- Covers all functions: displacement control, displacement control with open loop pressure control and displacement control with closed loop pressure control. Horse power control or horse power limitation respectively is always active with an installed pressure transducer.

## Technical Data

General	Unit	Description
mounting		Snap-On Module according EN 50022
housing material		Polyamid PA6.6
inflammation class	V	0 according UL 94
mounting position		any
environmental temperature range	°C	-20...+55
storage temperature	°C	-20...+70
protection class		IP 20 according DIN 40050
mass	g	260
Electrical	Unit	Description
duty cycle ED	%	100
supply voltage $U_s$	VDC	18...30, ripple < 5 % eff., surge free
rush in current peak, typ.	A	22 for 0,2 ms
current consumption, max.	A	< 2,0 for displacement control < 4,0 for p/Q-control
Supply line fuse	A	5,0 A medium slow-blow
Input signal options	$U_c$ V $I_c$ mA	0...+10, ripple < 0,01 % eff., surge free, $R_i = 25$ k $\Omega$ +4...+20, ripple < 0,01 % eff., surge free, $R_i = 250$ $\Omega$
Resolution of input command	%	<0.025, Horse Power control < 0.025
Digital Inputs $U_f$	V	Logic 0: <2 Logic1: >10 (and <30) Input resistance $R_i = 25$ k $\Omega$
Digital Inputs $U_{st}$	V	Logic 0: <2 Logic 1: >12 (50 mA) Max. load current: 30 mA
Diagnosis signal $U_d$	V	0...+10, max. load current max. 10mA, resolution input command 0,025 %
Serial Interface		RS232C, 9600...57600 Baud, 1 stop bit, no parity check, echo mode
Connectors		7x4 pol. connection blocks, screw PINs 0.2...2.5 mm <sup>2</sup> , plug-in style, USB-B, PE: via DIN rail
Connection to Computer		USB 2.0 Interface
EMC		EN61000-6-2: 8/2002 EN61000-6-3: 6/2005
Connection cable	mm <sup>2</sup> mm <sup>2</sup>	1.5 (AWG16) overall braid shield, for supply and solenoid cables 0.5 (AWG 20) overall braid shield, for sensors and commands
Maximum cable length	m	50
Reliability	y	MTTF = 228 MTTF <sub>d</sub> = 457



## 2. Security advice

Please read and follow this installation and setup manual before installation, setup, start up, service, repair and storage! Failure to follow the instructions herein can cause severe damage to the electronic or to the connected system.

### Symbols

This manual makes use of symbols, which have to be followed according to their meaning:



**Remarks with regard to warranty**



**Remarks with regard to possible damage to the electronic module or to any connected pump or part of the system**



**Helpful additional instructions**

### Name plates, markings

Information direct attached to the module like connecting diagrams and name plates are to be kept in readable condition.

### Work with electronics

Working in the area of installation and commissioning of the electronics should only be done by qualified personnel. This means persons which have, because of education, experience and instruction, sufficient knowledge on relevant directives and approved technical rules.

## 3. Important notes

### Intended usage

This operation manual is valid for module electronics **PQDXXA-Z10** series. Any different or usage beyond it is deemed to be as not intended. The manufacturer is not liable for warranty claims resulting from this.

### General instructions

We reserve the right for technical modifications of the described product. Illustrations and drawings within this manual are simplified representations. Due to further development, improvement and modification of the product the illustrations might not match precisely with the described unit. The technical specifications and dimensions are not binding. No claim may result out of it. Copyrights are reserved.

## Liability

The manufacturer does not assume liability for damage due to the following failures:

- incorrect mounting / installation
- improper handling and operation
- lack of maintenance
- operation outside the specifications

## Storage

In case of temporary storage the electronic must be protected against contamination, atmospheric exposure and mechanical damages.

## 4. Mounting / Installation

### Scope of Supply



Please check at receiving the shipment for damages due to shipping. Report damages immediately to the carrier, the insurance company and the supplier!



The programming cable (only for setup needed) is not part of the module shipment and has to be ordered separately. (please refer to page 3)

### Mounting

- compare electronic module type (see ordering code on name plate) with the parts list respectively the circuit diagram
- the module may be mounted in any orientation
- for mounting an assembly rail according to EN 50022 is required

### Mounting rail dimensions:

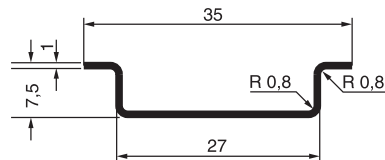



**Installation and removal of module from the rail**

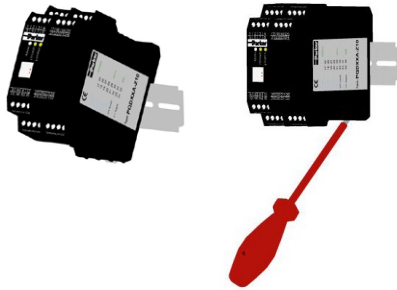

- Mounting:**
- 1 bring the module in contact with the upper edge of the rail
  - 2 flip the module downward until it snaps into/on the rail
- Removing:**
- 1 use a screw driver (approx. 4 x 1 mm blade) to lift metal socket
  - 2 flip the module upwards and remove it from rail

**Operating limits**

The electronic module may be operated within the specified limits only. Please refer to the „technical data“ section (please refer to page 6).

- ⚠ Follow the environmental conditions! Extreme temperatures, shock load, moisture, radiation, illegal electromagnetic emissions may result in malfunction and other operating issues. Follow the limitations listed in the „specifications“ table

**Electrical Connection**

The module is connected to power supply, machine control and to pump / valves with plug-in PIN screw blocks.

- 👉 This easy-to-install connection allows a fast module replacement.

The connecting wires need to match the specification below:

Wire type:	hook up cable, stranded
Cross section:	
supply voltage,	
solenoids:	min. AWG 16 / 1.5 mm <sup>2</sup>
sensors, commands:	min. AWG 20 / 0.5 mm <sup>2</sup>
Wire length:	max. 50 m

- 👉 for wire length > 50 m please consult the factory

**Wire stripping:**



The screw terminals are designed to connect to all kinds of copper wires without the need for specific preparation. To protect stripped wires the use of end sleeves is recommended.

- ⚠ Soldering of the connecting wires is not permitted.

To ensure EMC compatibility, the connections partly have to be shielded. See details in the „Electrical Interfacing“ section.

- ⚠ The installation must be performed by qualified personnel only. A electrical short between individual connectors, loose wires as well as improper shielding can result in malfunction of electronic or pump and in irreparable destruction of control module.

- ⚠ The pump has to have a direct connection to an earth grounded machine frame. An earth ground connection of the mounting rail and the cable shields have to be connected to the control unit earth ground terminal. Machine frame and control unit must be connected with a low resistance connection to avoid ground loops.

**Electrical Interfacing**

**Supply Voltage**

The supply voltage has to be connected to PINs 3 and 4 and to PINs 22 and 24. The supply voltage must be higher than 18 V to avoid sensor malfunction and lower than 30 V to avoid overheating and destruction of the module. The residual ripple may not exceed 5 %.

- ⚠ The power supply must comply with the relevant standards (e.g. DIN EN 61 558) and must carry a CE mark. The supply voltage must be free of inductive surges.

- ⚠ Please consider the high inrush current when selecting the power supply (see specification). Power supplies with current limiting features may cause problems during energizing the unit.

- ⚠ The function of the module is blocked, when supply voltage polarity is wrong.

- ⚠ Each module requires a preliminary fuse of 5 A, medium lag. Without a fuse, irreparable damage to the module or the pump control is possible.

**Wiring diagram**

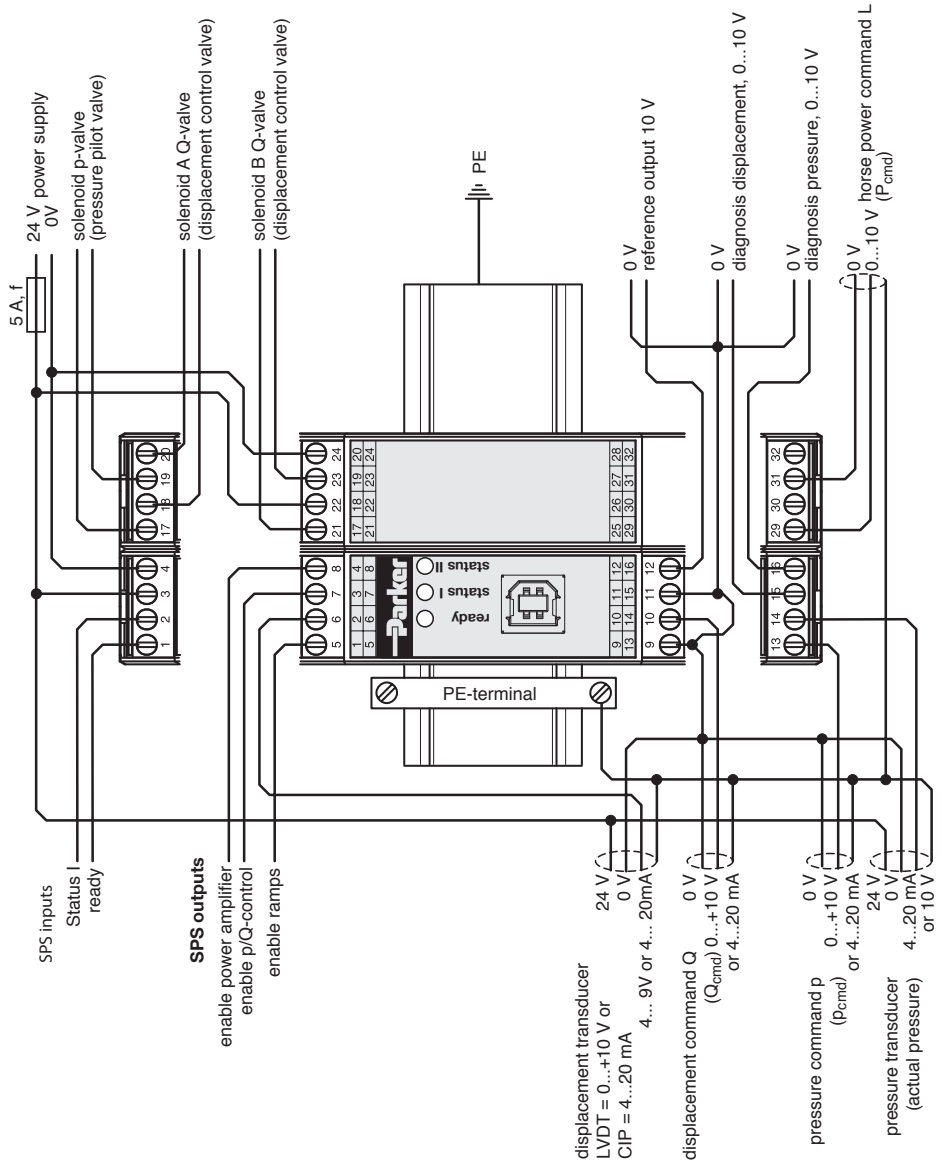

## Digital Inputs

### Enable

A positive voltage higher than 10 V (and < 30 V) at PIN 8 enables the solenoid current driver circuit of the module. The operation of the module requires a permanent signal on PIN 8 (e.g. supply voltage). Disconnecting the enable signal or a signal level below 2.5 V will immediately switch off the solenoid current. Ramp settings will not apply.



The enable function is not a safety function to avoid unwanted operation of the machine in terms of machine safety regulations.

### Enable p/Q-control

A positive signal > 10 V (and < 30 V) at PIN 7 enables the pressure control function of the module. A signal lower than 2.5 V at PIN 7 will allow the module to perform the displacement control of the pump only. The p-valve solenoid current is set to maximum. The amplifier for the pressure valve is deactivated at TYPE F (no function with mounted p-Q block)

### Enable ramp

A positive signal > 10 V (and < 30 V) at PIN 5 enables the internal ramp generator. The module offers an individual ramp-up and ramp-down function for displacement and pressure command. This ramp function allows ramp settings up to 60 s. A signal lower than 2.5 V at PIN 5 will disable the ramp generation.



Ramp function should be used for lasting system stability.

## Analog Inputs

### Displacement command signal input

The displacement command is connected to PIN 10.



Please note: all input commands as well as all output signals are referenced to the modules 0 V level at PIN 9, 11 and 31.

A +10 V input command at PIN 10 brings the pump to full displacement, when module settings and pump size are matched and if no electronic limitation is entered into the parameters. A 0 V input command at PIN 10 brings the pump to dead head (0 l/min output flow), when the pressure at the pump outlet is 20 bar or higher.

With the MAX setting for the displacement command (Parameter: MAX:WQ), a smaller displacement than the nominal pump displacement at +10 V input command can be adjusted. A minimum displacement at 0 V command signal can be set with the parameter MIN:WQ.



If the hydraulic system is not able to maintain a pump outlet pressure of 20 bar at pump dead head, a pre-load valve must be installed at the pumps outlet to maintain controllability of the pump displacement.



To prevent malfunction and erratic control response a high signal quality is recommended. The command signal needs to be filtered and must be free of inductive surges and modulations.



Incorrect signal levels will lead to erratic control function and may damage the unit. For correct signal levels, see the technical data section.



It is recommended to use shielded cables with a cross section of at least 0.5 mm<sup>2</sup> for the input command lines to avoid interference with power lines or other sources for electromagnetic „noise“.

### Pressure command signal input

The pressure command is connected to PIN 13. A +10 V input command brings the pump to the nominal pump pressure (350 bar for PV series pumps), if the pressure compensator differential setting is set in the module software and the pilot valve is the recommended type **PVACRE\*\*\*K35** (\* represents the mounting bolt options, thread options and the sealing options). A 0 V input command brings the pump to minimum compensating pressure (typical differential pressure + ca. 5 bar). The relation between input command and compensating pressure is linearized for the pressure control (open loop, TYPE=P). With a pressure transducer installed in the pilot circuit (at the pressure pilot valve PVAC\*\*\*K35), the compensating pressure is closed loop monitored (TYPE=Q). With the MAX setting for the pressure command (Parameter MAX:WP), a smaller pressure at +10 V input command can be adjusted.



To enable the pump to control pressures up to 350 bar the displacement command has to be at least 15 %.



To prevent malfunction and erratic control response, a high signal quality is recommended. The command signal needs to be filtered and must be free of inductive surges and modulations.



Incorrect signal levels will lead to erratic control function and may damage the unit. Please see the section technical data.

### Horse power command signal input

The horse power command is connected to PIN 29. A +10 V input command allows the pump to operate within its full power range (nominal displacement resp. flow, 350 bar output pressure). If the module is programmed for electronic horse power limitation (Parameter: PL:EXT = EXT), a reduced input command at PIN 29 will result in a limitation of the pump output flow, if the maximum power is exceeded.

The maximum pump driving power is calculated and stored internally in the module. The overall pump efficiency is considered in this calculation. A second maximum or limit can be set with the power limitation parameter (PL:PL), which can be less or equal to the calculated value.

If the external power limitation is deactivated (Parameter: PL:EXT = INT), the power limitation parameter defined in (Parameter: PL:PL) acts as boundary (only if a pressure sensor is installed). This will keep the horse power requirement of the pump below the commanded level.



A +5 V input command signal will limit the horse power requirement for the pump to 50% of the full nominal horse power (i. e. for PV028 the full corner horse power at 1,500 rpm is approx. 29,0 kW, at +5 V input command at PIN 29 the pump input power is limited to 14.5 kW).



Only for a constant input speed this control maintains a certain horse power level. For variable speed, only the max. input torque level is controlled.



If the power limitation is active, both LED STATUS I and STATUS II are on. The power limitation is also shown at the monitor view (Status Info – POWER\_LIM).

## Sensor signal

### Displacement Transducer – CIP

The displacement transducer (CIP) must be connected to the power supply (CIP connector PIN 1 to +24 V), to the displacement signal input (CIP connector PIN 2 to module PIN 6) and to the module 0 V CIP connector PIN 3 to module PIN 9 / 11). The displacement transducer signal is 4 mA when the pump is at dead head and 20 mA at full stroke. The connection to the displacement transducer is checked by the modules cable break monitoring

☞ Some electronics supply companies offer prefabricated cables with the M12x1 connector molded to the cable. These cables avoid the risk of mis-assembly, offer a higher protection against ingress of moisture or oil and are available in many different length options.

cable 1: 4 x 0,5 mm<sup>2</sup>, shielded  
connector: round plug connector type M12 x 1;  
4-PIN version

### CIP p/Q-module, control

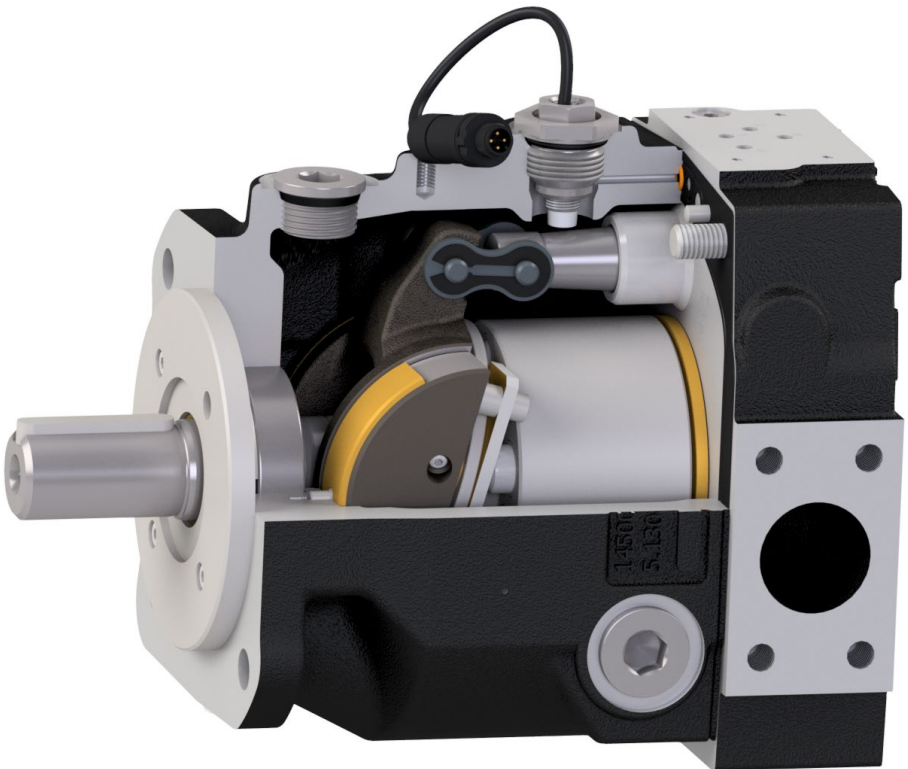
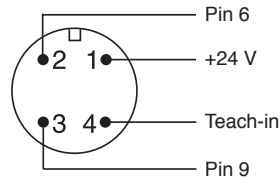

### Displacement Transducer – LVDT

The displacement transducer (LVDT) must be connected to the power supply (LVDT connector PIN 2 to +24 V), to the displacement signal input (LVDT connector PIN 1 to module PIN 6) and to the module 0 V (LVDT connector PIN 3 to module PIN 9 / 11).

The displacement transducer signal is 9 V (7.5 V at frame size 1 and 2), when the pump is at dead

head and between 7.5 and 4 V (depending on frame size and nominal displacement) at full stroke. The connection to the displacement transducer is checked by the modules cable break monitoring.

A sensor signal below 1 V or above 10 V will lead to a shut off of the power amplifier stages and will force the pump to dead head.

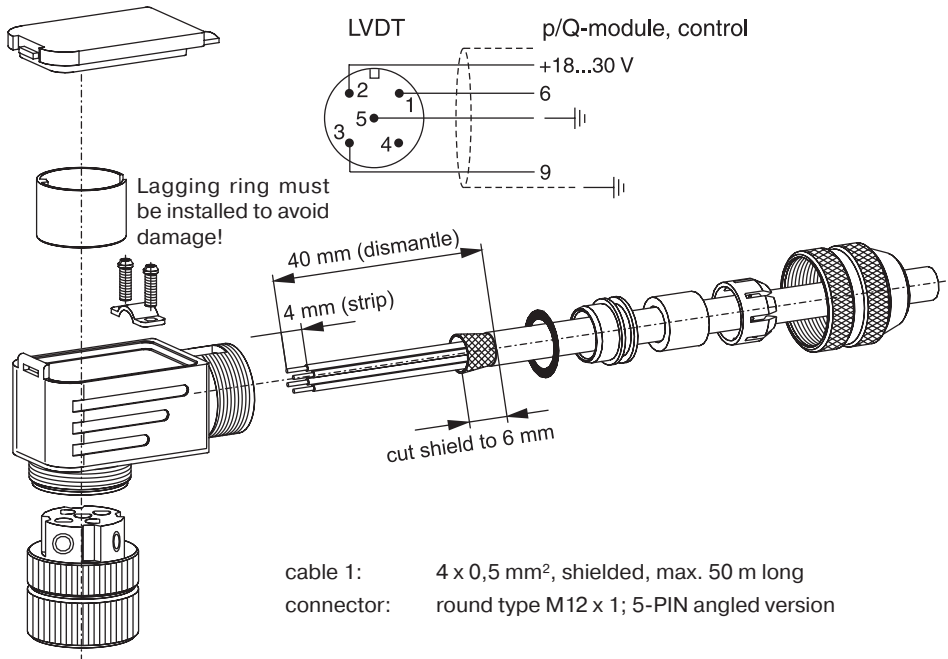

**!** The LVDT connector has to be assembled carefully to avoid the danger of a short circuit in the connector (i.e. the exact position of the lagging ring is to be checked). A electrical short in the connector can cause irreparable damage to the electronic module.

Some electronics supply companies offer prefabricated cables with the M12x1 connector molded to the cable. These cables avoid the risk of mis-assembly, offer a higher protection against ingress of moisture or oil and are available in many different length options.

Please note that the displacement signal is a voltage signal and the voltage drop is proportional to the cable length. The length of the cable should only be as long as necessary.

### Pressure Transducer (cable 2)

A pressure transducer is needed, when the module is set to closed loop pressure control (TYPE = Q) or if the circuit requires a internal or external horse power control.

The pressure transducer must be connected to the power supply (connector PIN 3 to +24 V), to the pressure transducer signal input (connector PIN 1 to module PIN 14) and to the module 0 V level (connector PIN 2 to module PIN 9 / 11). The pressure transducer signal is between 4 mA

(current signal) at 0 bar and 20 mA at the transducers nominal pressure of 600 bar. The normal working range in case of a PV series pump is 4...11.67 mA (0...350bar).

The connection to the pressure transducer is checked by the modules cable break monitoring. A current below 3 mA will lead to a shut off of the power amplifier stages and will force the pump to dead head.

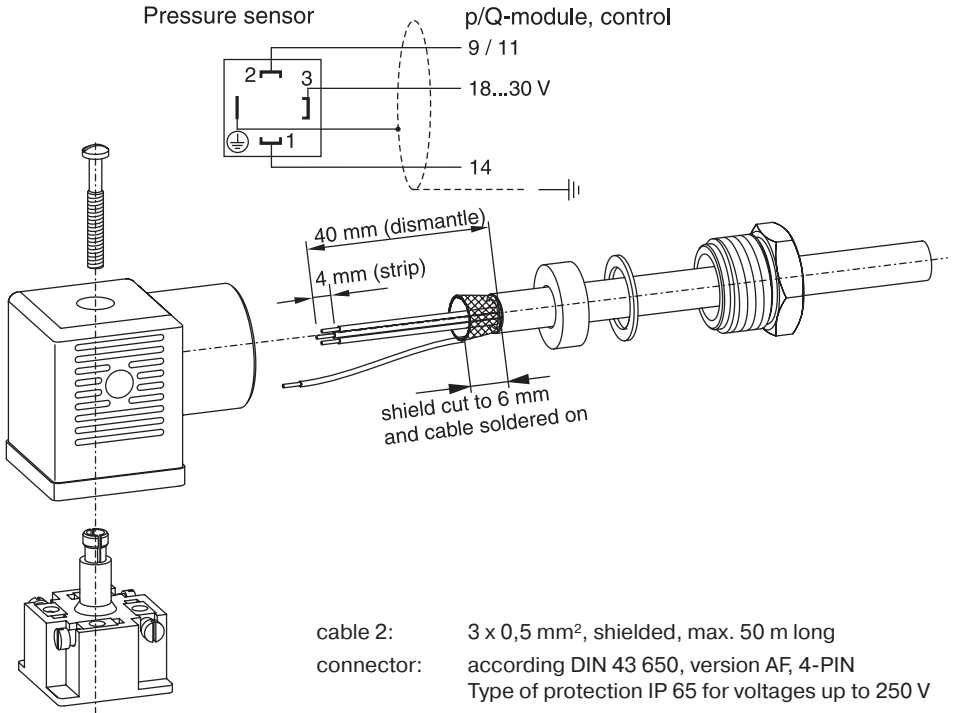

## Solenoid Connections

### Displacement control valve solenoid (cable 3a/3b)

The displacement control valve (Q-valve) solenoid - A must be connected to PIN 18 (connector PIN 1) and PIN 20 (connector PIN 2) of the control module.

The displacement control valve (Q-valve) solenoid - B must be connected to PIN 21 (connector PIN 1) and PIN 23 (connector PIN 2) of the control module.

The current to the solenoid is between 0 and 2,7A for the usage of a **PVCM D1FB\*\*\***.

The current to the solenoid is between 0 and 1,3 A for the usage of a **PVCM\*PV\*\***.

The nominal current in a constant displacement control situation is in the range of 720 mA to 750 mA, to operate at half of the solenoids nominal force.

### Pressure pilot valve solenoid (cable 4)

The pressure pilot valve (p-valve) solenoid must be connected to PIN 17 (connector PIN 1) and PIN 19 (connector PIN 2) of the control module. The module supplies a current between CP: MINV and CP:MAXV to the solenoid.

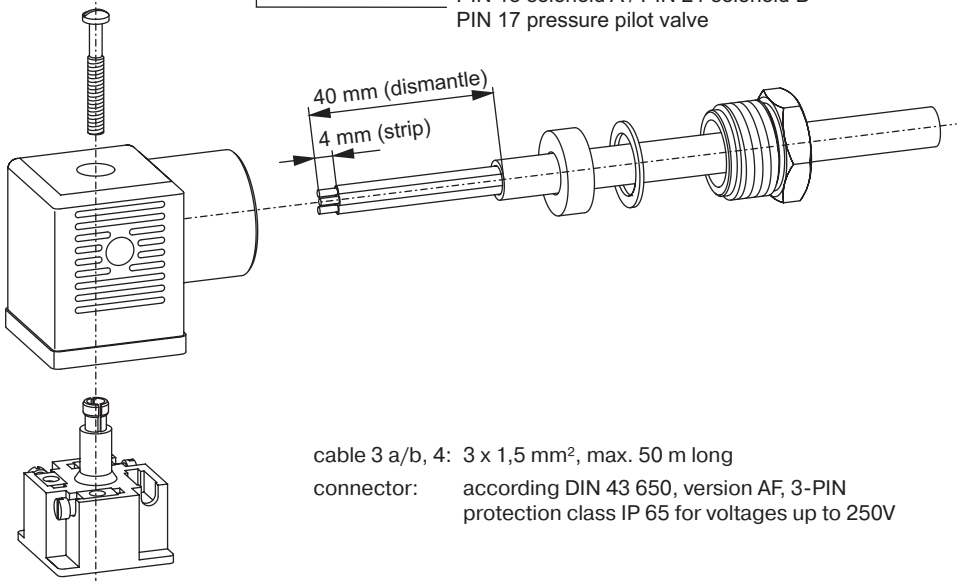
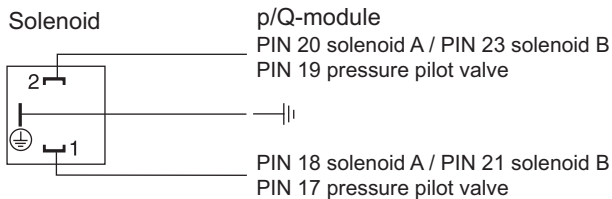



## Analog Outputs

### Diagnosis displacement

PIN 15 provides an analog readout proportional for the actual pump displacement. The signal is +10 V at full stroke and 0, 15 V at dead head and stand-by pressure, if the LVDT adjustment is correct and the programming of the module matches the actual pump size and displacement. The maximum current load to this output is 10 mA.

### Diagnosis pressure

PIN 16 provides an analog readout for the actual pressure, when a pressure transducer is installed and the module is programmed. The signal is +10 V at nominal pressure (350 bar) and 0 V at 0 bar pump outlet pressure. The maximum current load to this output is 10 mA.

### Reference voltage output

PIN 12 provides a stabilized +10 V reference signal, which can be used to drive potentiometers for the analog input signals. The maximum current load for the reference output is 10 mA.

## Digital outputs

### Ready

The **Ready** output (PIN 1) gives information on the module being ready to operate. A signal larger than +10 V signals a logic 1, a signal lower than +2 V signals a logic 0. PIN 1 has a logic 1 signal, when all necessary sensors are attached and

intact and the **Enable** signal is set (logic 1 at PIN 5). The control loop is closed under these conditions. The Ready LED (green) is lighted.

When a sensor fault occurs (cable broken, no sensor connected, signal out of range, or wrong pump size selected) a logic 0 is sent. The Ready LED starts flashing.

















### Status

The **Status I** output (PIN 2) delivers via switch sequence information about the error category. Memory, command, sensor and solenoid errors can be evaluated. A signal higher than +10 V signals a logic 1, a signal lower than +2 V signals a logic 0. The signals at PIN 2 are also shown as flash sequence at LED Status I.

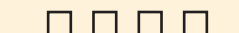
In addition the LED **Status II** gives information about the error description. The switch sequence at PIN 2 and the flash sequence at LED Status I for the error category and the flash sequence at LED-Status II for the error description are described in the picture shown below.

The display of error category and error description eases the field error diagnosis.

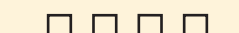
The activity of the horse power control is shown via a static signal at the **Status I** and **Status II** LED. If the total input power is within the specified corner power, both Status LEDs are off. Status I is a logic 0. During fast control actions both status LEDs will flicker.

Error Category	Error Description	STATUS I	STATUS II
EEPROM	Memory Error		
Command Signal	Command Signal Pressure		
Command Signal	Command Signal Swivel Angle		
Sensor	Pressure Sensor		
Sensor	Swivel Angle Sensor		
Solenoid	Pressure Valve		
Solenoid	Q-Valve (Solenoid A)		
Solenoid	[Q-Valve (Solenoid B)		

**Module status depending on digital inputs:**

ENABLE	ENABLE pQ	RAMPE	Description
off (0)	-	-	System not active, analog outputs switched off, <b>READY</b> signal is off (0). Control loop not closed.
on (1)	off (0)	-	System active, displacement control loop closed, <b>READY</b> signal is <b>on (1)</b> . Pressure control loop is not active.
on (1)	on (1)	-	System active, displacement control loop closed, <b>READY</b> signal is <b>on (1)</b> . Pressure control loop is active.
on (1)	-	on (1)	System active, displacement control loop closed, <b>READY</b> signal is <b>on (1)</b> , Ramps for displacement commands and pressure command are activated.

☞ In case of using a pump with p-Q block and demand of displacement control only, the control TYPE needs to be adjusted to TYPE=P and Enable pQ needs to be deactivated. The pressure valve will be fully activated.

## 5. Programming

The Programming of the p/Q-module can be done in an easy way. For programming the module must be connected with the PC via a programming cable (Ordering number **PQDXXA-ZXX-Kabel**). The **ProPVplus** Software need to be installed and started on the connected computer to get the module parameterized. The program runs under WINDOWS XP, WINDOWS VISTA, WINDOWS 7 and WINDOWS 8.

 The latest version can be downloaded at:  
<http://www.parker.com/pmde> →  
**Support → Customer Toolbox**

 The **PQDXXA-Z10** module is compatible to ProPVplus 3.5.0 upwards.

 Please note that the data format has been changed from since module generation **PQDXXA-Z01** .PAR to .WPC. Old .PAR parameter sets cannot be translated to the new data format.

### The software offers the following features:

The **PARAMETER LIST**  displays all available and changeable parameters. Two different input levels are available (MODE = STD or EXP). An

input dialog opens after double clicking on the parameter. Limits of the input are shown, faulty or wrong inputs are identified.

All parameters are directly sent to the module, if it is in active mode, which means ProPVplus is connected with the module [**CONNECT** ]. The command: Save, saves the parameter settings to the modules memory. Default, resets the module to factory settings. Load Back, resets the module to the last saved parameter settings. Parameter sets can also be edited offline without any connection to the module.

The **MONITOR**  window allows the numerically display of various process parameters.

The **OSCILLOSCOPE**  displays various process parameters as graphs. Furthermore the oscilloscope offers a Start-Stop option and allows the data export as well as the storage as text file (.txt).

The cursor function in the right mouse button menu provides the option for amplitude and time measurements. Screenshots can also be captured with the right mouse button dialog.

 Please see the documentation in the software ProPVplus under Menu → Help for further information about the handling of ProPVplus.

When starting ProPVPlus and an activated connection to the module, the screen shown below will be displayed:

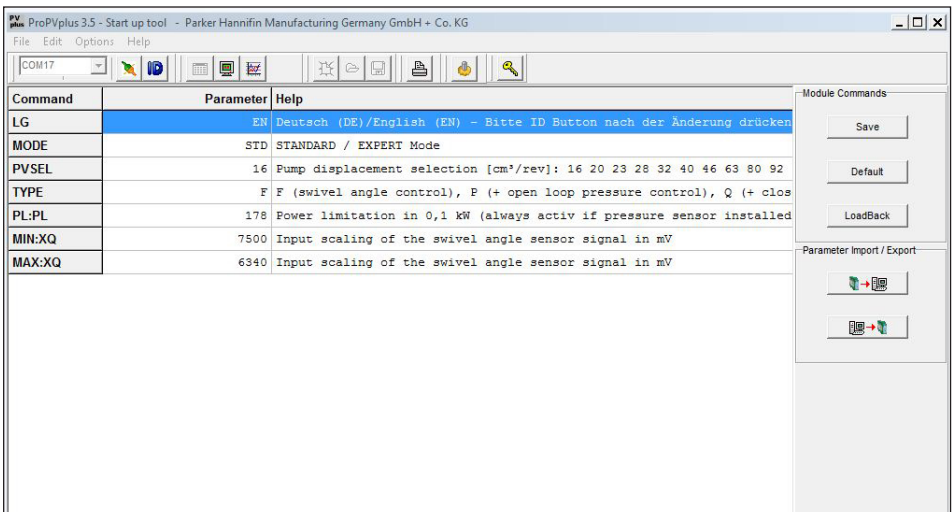

**Terms for the oscilloscop- and monitor view:**

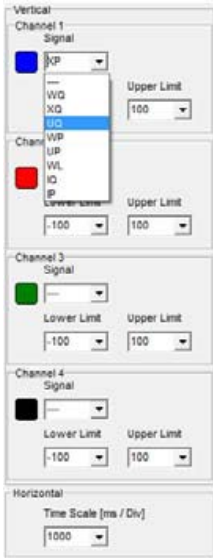

**Displacement Control:**

- WQ Displacement command in %
- XQ Displacement actual value in %
- UQ Correcting variable displacement control in %
- XQ\_R Displacement actual value in V or mA
- IQ:A Current to solenoid A (displacement control valve) in mA
- IQ:B Current to solenoid B (displacement control valve) in mA
- Q:P P-Gain in % (Sum of offset CQ:FF and P:Gain)
- Q:I I-Gain in %
- Q:D D-Gain in %

**Pressure Control:**

- WP Pressure command in bar
- XP Pressure actual value in bar
- XP\_R Pressure actual value in V or mA
- UP Correcting variable pressure control in %  
(only if pressure transducer is installed)
- IP Current to the pressure control valve in mA
- P:P P-Gain in % (Sum of offset and P-Gain)
- P:I I-Gain in %
- P:D D-Gain in %

**Horse Power Control**

- WL Horse Power command in %
- PL:EXT → Calculated out of the Command signal at PIN 29,  
Parameter PL:PL is the maximum value
- PL:INT → Calculated from the input of Parameter PL:PL
- XL Internal calculated maximum swivel angle in %

 All Parameters are displayed with a resolution of 0,01. Please mind the units.

 Parameters shown in the Oscilloscope are sampled with 1 ms. The solenoid current has a lower sampling rate. Please take the solenoid display only for informational purpose, but do not take these values for quantitative validation.

 Do not start up a pump or hydraulic system before loading the correct control program for the particular pump size to the attached module. Damage of the pump or components connected to it can be the result.



## 6. Operating Parameters

 Latest parameter sets are available for download at:  
<http://www.parker.com/pmde> → Support  
→ Customer Toolbox.

### LG (help text / parameter description language):

DE = German, Display of help texts and parameter descriptions in German.

EN = English, Display of help texts and parameter descriptions in English.

 The module need to be re-identified (IDENTIFY ) after changing this parameter.

### MODE (security level):

STD = Standard, All parameters for a first start up are shown.

EXP = Expert, Parameter for further settings and the control system optimization are shown additionally to the standard parameter list.

### 6.1 MODE – Standard (STD)

#### PVSEL (pump displacement):

PVSEL 016, 020, 023, 028, 032, 040, 046, 063, 080, 092, 140, 180, 270, 360 or CUSTOM (additional parameterizable data set).

 The base parameter for the control circuit are loaded according to the PVSEL parameter.

 **PVSEL needs to be adjusted first because various parameters are set according to this selection. Otherwise other parameter changes might have no effect.**

#### TYPE (Selection of control type):

F = Displacement control

P = Displacement control with open loop pressure control

Q = Displacement control with closed loop pressure control

S = Digital switch for displacment. Max current to solenoid A if comand signal > 6 V, the pump strokes up. Max current to solenoid B if comand signal < 4 V, the pump strokes down.

 TYPE S functionality is only available if SENS = OFF.

#### CO (control option)

FD\* / UD\* prop. directional valve **PVCMD1FB\*\*\***  
FP\* / UP\* prop. directional valve **PVCM\*PV\*\***

 **The parameter CO (control option) is beside the parameter PVSEL very important for the selction of the base parameter set.**

#### DS:P\_valve (pressure valves design series)

Selection of the pressure valves design series. The parameter defines the presetting of CP:MAXV. The parameter is to be set according to the valve type plate!

#### PL:PL (horse power control setting):

Selection of horse power control in 0,1 kW. The parameter is freely selectable, where the upper limit equals the pumps maximum input power, which is calculated by the module internally. The lower limit equals 10 % of the pumps maximum input power.

 The rotational speed of the drive motor is used for the calculation of the pumps maximum input power. Please mind the correct adjustment. The standard adjustment of the parameter PL:RPM is set to 1500 rpm.

## Displacement sensor adjustment:

### ATTENTION!

 In **PQDXXA-Z10-r08** current signal is defined as standard signal.

### CIP setting

MINC:XQ Displacement sensor feedback at dead head (CIP-0 %) in mA.

MAXC:XQ Displacement sensor feedback at full stroke (CIP-100 %) in mA.

### LVDT setting

MODE „EXP“ → AIN:XQ = „V“

MIN:XQ Displacement sensor feedback at dead head (LVDT-0 %) in V.

MAX:XQ Displacement sensor feedback at full stroke (LVDT-100 %) in V.

 Both parameters are shown at the pump enclosed tag.

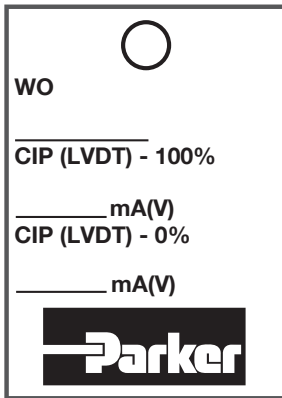

 Pumps are tested at a fluid temperature of  $(50 \pm 2)^\circ\text{C}$ . Small deviation of the LVDT parameters are possible if the hydraulic system temperature where the pump is used is significant different. In this case, the values need to be re-measured with a convenient voltmeter and redefined in the software.

## 6.2 MODE – EXPERT (EXP) TRIGGER (Response Delay):

The response delay describes a kind of dead band (in 0,01 % of full scale) to compensate for unwanted command signal changes (e.g. ripple in the command signal) and command signal noise in p and Q.

 TRIGGER influences the command signals transfer and processing. The pumps small signal quality is indirect proportional to the TRIGGER parameter.

 A value of 1000 indicates a pump reaction with command signal of 1V. The rest of the command value 1 – 10 V is equal distributed to 100 % WP or WQ respectively (e.g. 50 % actual value is reached with 5,5 V).

## SOLENOID (Number of solenoids of the Displacement control valve):

Selection of the number of solenoids at the Displacement control valve.

 With the change of parameter SOLENOID, CQ:MINVA CQ:MINVB, CQ:MAXVA, CQ:MAXVB and CQ:FF need to be adjusted as well.

## CC / CC MODE (Linearization of the pressure valve):

CC Activation of the pressure valve linearization function.

CCMODE Adjustment of the pressure valve Linearization, via „drag & drop“ or direct input of the correction parameter.

Input dialog – without correction

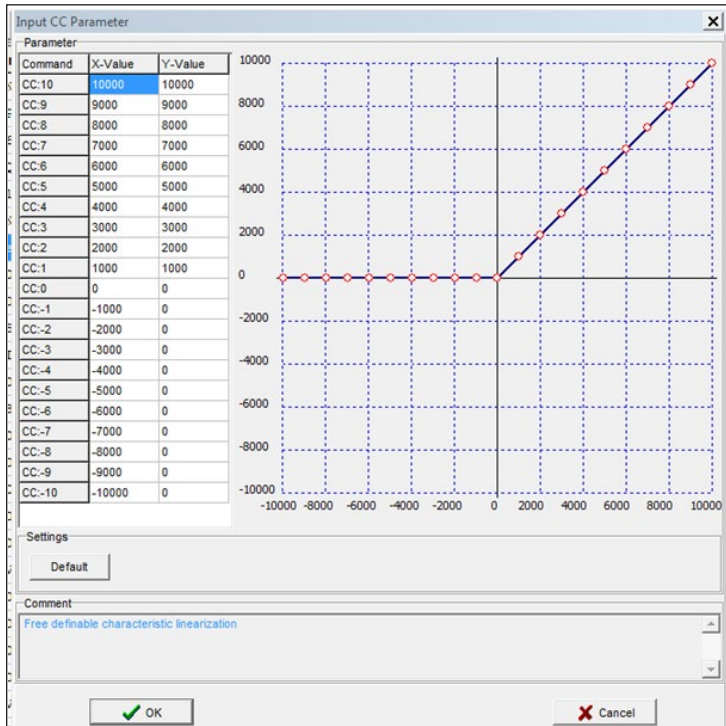

Valve performance – without correction

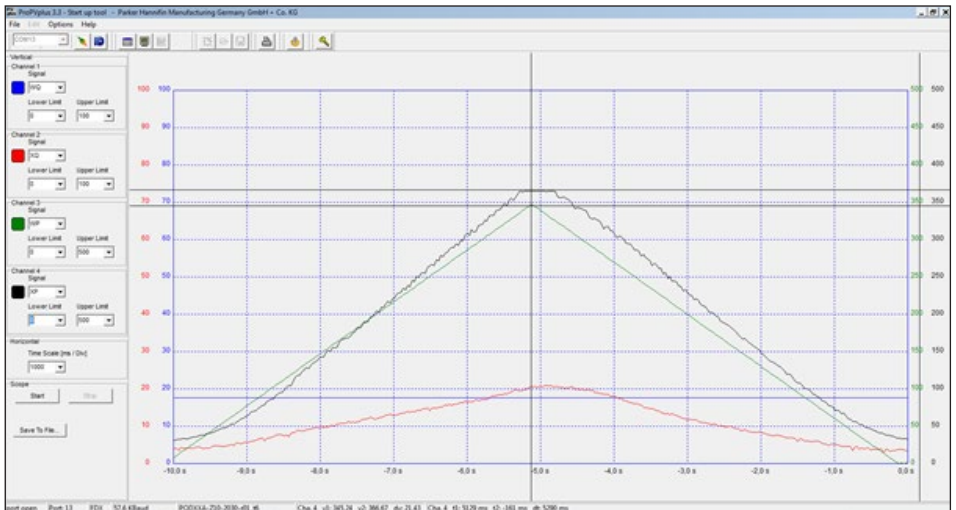

Input dialog – with correction for rising functions

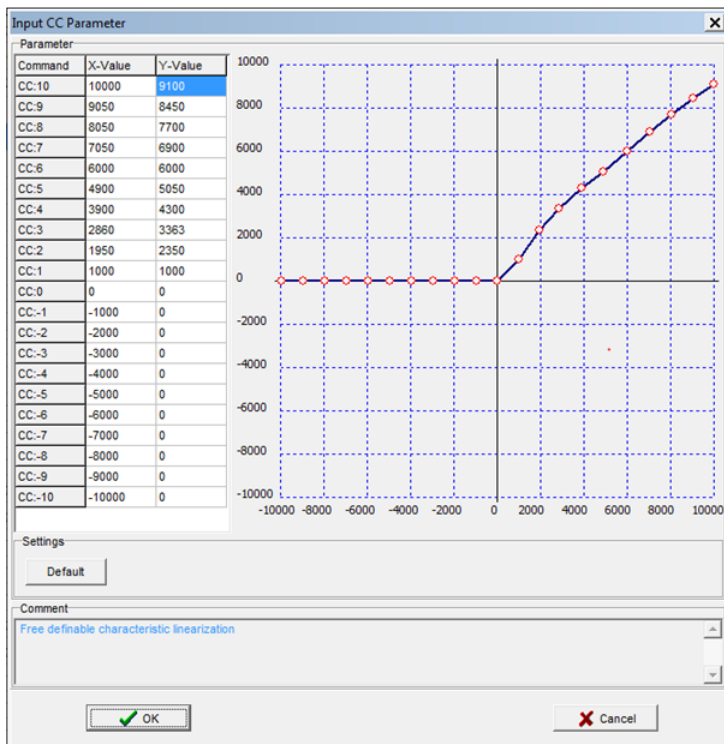

Valve performance – with correction for rising functions

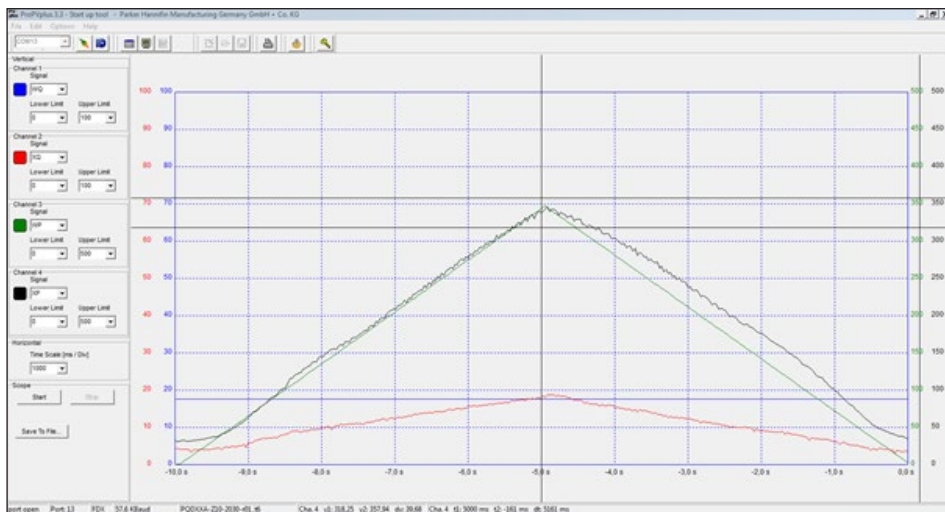



Input dialog – with correction for falling functions

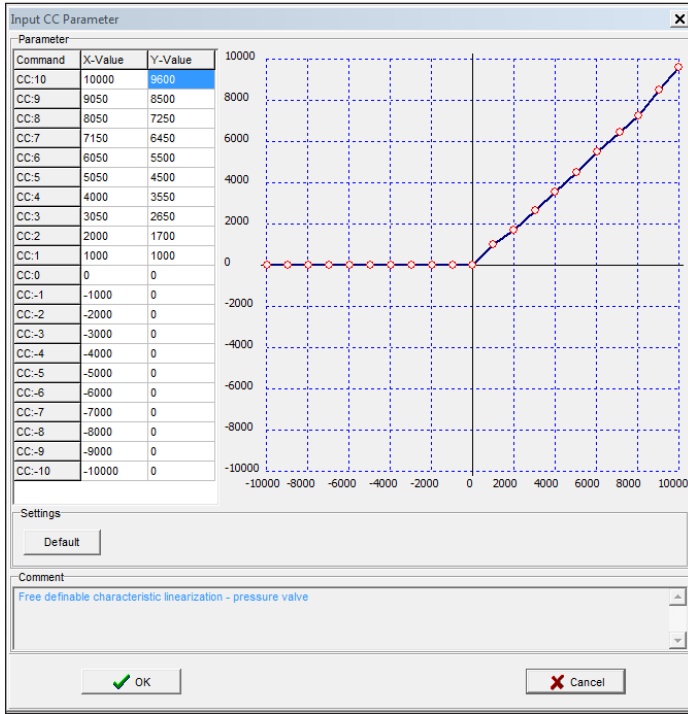

Valve performance – with correction for falling functions

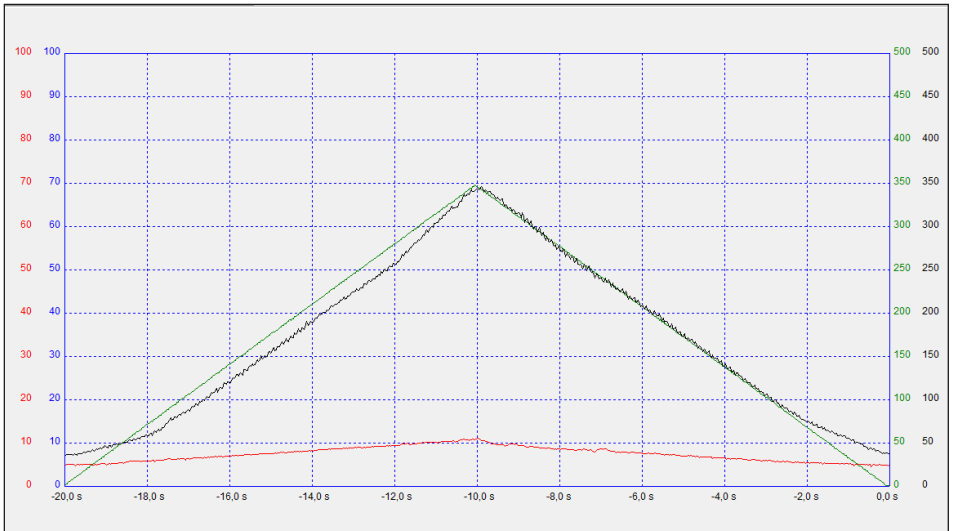

☞ The Linearization is only active at TYPE P. Due to pressure valves hysteresis only ascending or descending pressure functions can be optimized.

#### **P\_SENSOR (Pressure sensor end range):**

Setting of pressure sensor end range in bar. This parameter is base for the scaling of the sensor with the parameter P\_NOMINAL.

☞ P\_SENSOR is by default set to 600 bar.

☞ For the control options UDM, UDF, UDQ (old: UPM, UPF, UPQ) the 600 bar sensor (**PVACMS**, SCP01-600-24-06) is used as standard.

#### **P\_NOMINAL (Pressure sensor scaling):**

Setting of pressure sensor scaling in bar. This parameter determines the upper limit for the pressure sensor signal.

⚠ Changing this parameter may cause negative effects to your system. A new adjustment of the pressure valve solenoid limitation (Parameter CP:MINV and CP:MAXV) might be necessary!

☞ In case of running the pump with a **PVACRE\*\*\*K42** as pilot pressure valve, this parameter has to be set to 420 bar. A new adjustment of the pressure valve solenoid limitation (Parameter CP:MINV and CP:MAXV) might be necessary!

☞ The parameter P:NOMINAL shall match the pressure pilots end range.

#### **P\_CORR (differential pressure setting, compensator):**

Setting of the differential pressure in bar.

☞ The factory standard setting of the compensator differential pressure is 15 bar.

☞ P\_CORR needs to be adjusted to 0 bar in case of installing the pressure transducer in the pumps outlet.

☞ The differential pressure is a numerical constant, which is added to the sensor pressure signal all of the time. If the pump acts in displacement control, the constant is added as well. The system pressure equals in this case actual pressure (XP) minus P\_CORR.

#### **PL:EXT (horse power mode):**

INT The setting in PL:PL is getting active as horse power limitation.

EXT The horse power control gets dynamic by an analog 0...10 V Signal at PIN 29 while the setting at PL:PL gets 100 % (maximum value) for the scaling.

☞ The horse power control is only active if a pressure sensor is installed.

#### **PL:RPM (Rotational speed setting):**

Setting of the pumps or drive motors rotational speed respectively.

☞ The parameter is used for the calculation of the maximum input power.

#### **PL:T1 (Setting of the horse power controls delay element):**

Setting the horse power controls delay element. The time between signal input and signal processing of the horse power controlled subsystem can be modified with that parameter.

☞ This parameter should be changed only if the controlled system tends to have instabilities due to high dynamic challenges.

☞ When the module is operated in horse power control mode under certain conditions and at fast pressure rise rates the power limiter may act too slowly and the horse power requirements exceed the limits briefly.

**Q:CORR (Correction of the pumps volumetric efficiency):**

This parameter describes the compensation of the pumps volumetric efficiency and builds a linear correction function vs. pressure which

output is added to the Q-command signal. The Q-controls variable limitation is thereby still 100 %.

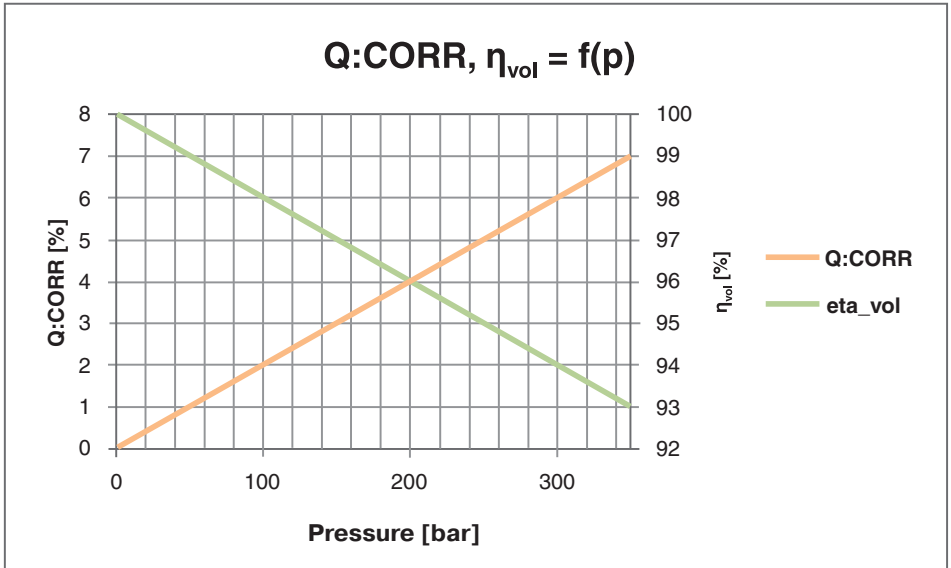

Example Illustration Q:CORR, ηvol vs. p

👉 The usage of ramp functions (Parameter AQ:UP, AQ:DOWN) is recommended.

**Recommended values for Q:CORR:**

Frame size	Pump displacement [cm <sup>3</sup> /rev.]	System pressure [bar]	Q:CORR [0,01%]
1	16	350	1223
1	20		933
1	23		770
1	28		710
2	32		877
2	40		610
2	46		593
3	63		887
3	80		733
3	92		453
4	140		693
4	180		530
5	270		350
6	360		303

### SENS (Setting of the Sensor monitoring):

- ON Sensor monitoring is activated. The Reset has to be done manually. The error will be shown at the module and in the Monitor view until the reset.
- OFF Sensor monitoring is deactivated.
- AUTO Sensor monitoring is activated. The module gets automatically reset after the failure or the defect is corrected. A manual reset is not necessary.

 The manual reset is done by switching the **ENABLE** signal at PIN 8.

 The module monitors signals from the displacement sensor as well as from the pressure sensor according to a specified range and the electric circuit to the valve magnets. Signals out of the specified range (pressure sensor < 3 mA, displacement < 1 V) or an opened electric circuit (broken cable detection) are detected as failure. The module will force the pump to dead head. The green **READY** LED is flashing. The error category and the error description are shown via the Status LEDs (please see chapter 4).

 The pressure sensor is not monitored at TYPE F and P.

### MIN:WQ / MAX:WQ (Setting of the displacement command scaling):

MIN:WQ Setting of the lower limit of the internal displacement command signal.

MAX:WQ Setting of the upper limit of the internal displacement command signal.

 MIN:WQ and MAX:WQ can be used to set a minimum displacement respectively a maximum displacement without changing the command signal resolution 0 – 10 V.

### AIN:WQ (Command signal type – Displacement Control):

The command signal of the displacement control can either be a current signal [C, 4 – 20 mA] or a voltage signal [V, 0 – 10 V]. Default setting is a voltage signal.

 Voltages at PIN 10 are not monitored by the broken cable (**SENS**) detection.

### AQ:UP / AQ:DOWN (Ramp times – displacement control):

AQ:UP Ramp time settings for rising displacement commands in ms.

AQ:DOWN Ramp time settings for dropping displacement commands in ms.

 It is recommended to activate ramps to achieve sustainable system stability. Ramps can be activated with a suitable voltage signal to PIN 5 / RAMP ON.

 Ramp times in the software refer to a command step of 100% and define the ramp gradient. Ramp times are proportional to the percentage of the command steps.

**Default ramp times – recommended ramp times for displacement control:**

Frame size	Pump displacement [cm <sup>3</sup> /rev]	System pressure [bar]	Ramp time [ms]	
			Rising command values	Falling command values
			FD* / UD*	FD* / UD*
1	16	350	33	41
1	20		37	46
1	23		40	51
1	28		44	57
2	32		47	62
2	40		51	67
2	46		54	72
3	63		58	78
3	80		61	83
3	92		65	88
4	140		87	112
4	180		110	136
5	270		132	159
6	360		154	183

**MIN:WP / MAX:WP (Setting of the pressure command scaling):**

MIN:WP Setting of the lower limit of the internal pressure command signal.  
 MAX:WP Setting of the upper limit of the internal pressure command signal.

 MIN:WP and MAX:WP WQ can be used to set a minimum pressure without changing the command signal resolution 0 – 10 V.

**AIN:WP (Command signal type – pressure control):**

The command signal of the pressure control can either be a current signal [C, 4 – 20 mA] or a voltage signal [V, 0 – 10 V]. Default setting is a voltage signal.

 Voltages at PIN 14 are not monitored by the broken cable (**SENS**) detection.

**AP:UP / AP:DOWN (Setting of ramp times – pressure control):**

AP:UP Ramp time setting for rising pressure command signals in ms.

AP:DOWN Ramp time setting for dropping pressure command signals in ms.

 It is recommended to activate ramps to achieve sustainable system stability. Ramps can be activated with a suitable voltage signal to PIN 5 / RAMP ON.

 Ramp times in the software refer to a command step of 100% and define the ramp gradient. Ramp times are proportional to the percentage of the command steps.

 **The optimal ramp time setting is for pressure control depending on the system, it is especially depending on the hydraulic capacities and the different operating points. The set-up at the specific system may help to optimize the pressure control.**

**AIN:XQ (Sensor signal type – displacement sensor):**

The displacement sensors signal can either be a voltage signal [V, scalable via MIN:XQ and MAX:XQ] or a current signal [C, 4 – 20 mA].

 If the voltage signal at PIN 6 is 0,5 V lower than MAX:XQ (at machines off-state) the module switches to error mode. This function is to see if the sensor scaling is done and if the right displacement has been chosen in the parameter list.

**AIN:XP (Sensor signal type – pressure sensor):**

The pressure sensor signal can either be a current signal [C] or a voltage signal [V].

 Voltage signals at PIN 14 are not enclosed in the error detection (SENS).

 The current signals default range is 4 mA to 20 mA.

 The voltage signals default range is 0 V to 10 V.

 Further pressure related settings are done with the parameter P\_SENSOR, P\_NOMINAL and P\_CORR.

**CQ:P / CQ:I / CQ:D (PID parameter – displacement control):**

CQ:P P gain setting in 0,01 units.

 P gain is deactivated with input 0.

CQ:I I gain setting in 0,1ms.

 I gain is deactivated with input 0.

CQ:D D gain setting (time factor for differentiation) in 0,1ms.

 D gain is deactivated with input 0.

CQ:T1 Filter of D gain in 0,1ms.

 D gain filter is deactivated with input 0.

**CP:P / CP:I / CP:D (PID parameter – pressure control):**

CP:P P gain setting in 0,01 units.

 P gain is deactivated with input 0.

CP:I I gain setting in 0,1ms.

 I gain is deactivated with input 0.

CP:D D gain setting (time factor for differentiation) in 0,1ms.

 D gain is deactivated with input 0.

CP:T1 Filter of D gain in 0,1ms.

 D gain filter is deactivated with input 0.

 The PID parameter tuning will help to optimize the hydraulic system.

**CQ:MINVA / CQ:MINVB (Dead band compensation – displacement control valve):**

- CQ:MINVA Dead band compensation solenoid A in mA.
- CQ:MINVB Dead band compensation solenoid B in mA.

- ☞ The dead band compensation is only reasonable for displacement valves with 2 solenoids.
- ☞ The valves offset, parameter CQ:FF needs to be set to zero "0" when using a displacement control valve with two solenoids.
- ☞ The dead band compensation needs to be aligned to the parameter OFFSETQ.

**CQ:MAX:VA / CQ:MAXVB (Nominal current – displacement control valve):**

- CQ:MAXVA Nominal current to solenoid A in mA.
- CQ:MAXVB Nominal current to solenoid B in mA.

**TRIGGER Q (Threshold for command signals):**

The response delay describes a kind of dead band (in 0,01 % of full scale) to compensate unwanted command signal changes (e.g. ripple in the command signal) and command signal noise.

- ☞ This parameter is only active with SOLENOID = 2.

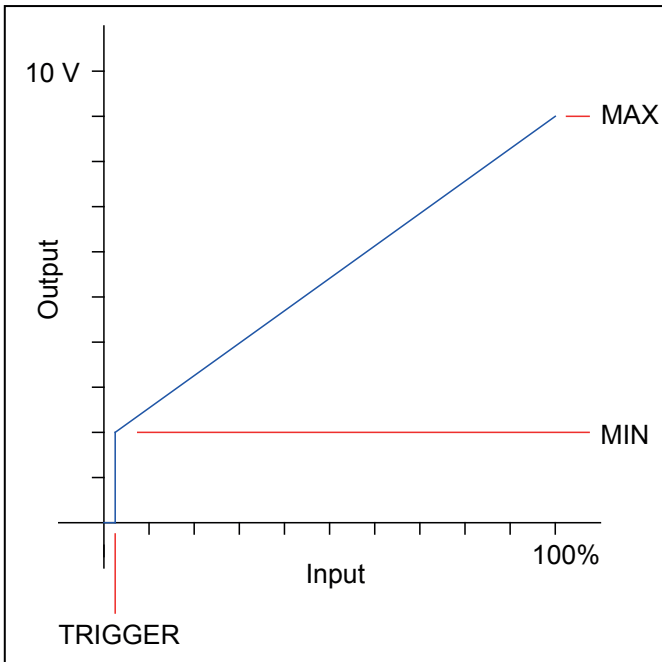

### OFFSETQ (Adjustment of Q-valves hydraulic neutral point)

Adjustment of the Q-valves hydraulic neutral point in %. A positive input is acts to solenoid A, a negative acts to solenoid B.

### CP:MINV (Trigger threshold – pressure control valve):

Trigger threshold of pressure control valve in mA.

### CP:MAXV (Nominal current – pressure control valve):

Nominal current of the pressure control valve in mA.

It might be necessary to fine tune the trigger threshold CP:MINV and the nominal current CP:MAXV to get optimal results in open loop pressure control.

## 6.3 MODE – Offline (PARKER EXP)

### TS (Sample Time)

The sample time (in 100  $\mu$ s) describes how often the signals is processed internally. The parameter TS represents the controls cycle time and there-with controls dynamic.

Changes should be performed only if enough knowledge about the dynamic system behaviour is available. Changing TS requires that all time depended parameters need to be checked and possibly readjusted.

### PMode (Closed Loop Control Functions)

The closed loop pressure control can be driven with the MR control or with the PID control.

Currently only the PID control is supported.

### PL:EFF (Mechanical Pump Efficiency)

Mechanical pump efficiency in 0,01 %.

PL:EFF is used for the calculation of the corner power and therewith the maximum of parameter PL:PL.

$$PL : PL_{MAX} = \frac{(PVSEL) \cdot (PL : RPM) \cdot (P\_NOMINAL)}{(PL : EFF) \cdot 6} [0.1 kW]$$

### CQ:FF (Offset-Displacement Control Valve)

Offset parameter (in 0,01 %) to adjust the displacements control valve neutral point.

The Offset parameter is only needed for valves with one solenoid. The parameter needs to set to 0 in case of using a valve with two solenoids .

In a control situation, the solenoid should draw approx. 60 % of its nominal current (nominal current 1,3 A; current in control situation 780 mA). Under these conditions the solenoid provides approx. 50 % of its nominal force. That leads to a similar response for on- and off stroking.

### CQ:I\_LIM (Integrator Limitation)

Integrator limitation of the closed loop displacement control in 0,01 %.

The integrator compensates the systems nonlinearities only. Therefore this parameter should be chosen as small as possible.

Typical value = 2500 (25 %). Depending on systems linearity this value can also be higher.



### CQ:IC (Integrator Activation)

Integrator activation of the closed loop displacement control in 0,01 % (of full scale).

 This parameter works as threshold value for the integrator activation (Q-PID controller). If the actual pressure value is higher than the command value, the integrator freezes. If the actual pressure value falls below the programmed threshold between command and actual value, the integrator is enabled again.

 This function shuts down with CQ:IC = 0. In this case, the integrator is active all time.

### CP:FF (Offset Pressure Control Valve)

Offset parameter (in 0,01 %) to open the valve controlled.

 This Typical value = 8000 ... 9000.

### CP:I\_LIM (Integrator Limitation)

Integrator limitation of the closed loop pressure control in 0,01 %.

 The integrator compensates the systems nonlinearities only. Therefore this parameter should be chosen as small as possible.

 Typical value = 2500 (25 %). Depending on systems linearity this value can also be higher.

### CP:IC (Integrator Activation)

Integrator activation of the closed loop pressure control in 0,01 %.

 The Integrator gets activated within these limits (in % of full scale). This reduces the

overshoot while starting the closed loop control.

 Typical value = 500...5000.

 This function shuts down with CQ:IC = 0. In this case, the integrator is active all time.

### MR:T1 (system time constant)

System time constant in 0,1 ms (typical = 0,5 T2) in 0,1 ms.

### MR:T2 (system time constant)

System time constant in 0,1 ms.

 MR:T1 and MR:T2 are parameters for the MR control. Currently only the PID control is supported.

### DFREQ:Q (Dither Frequency)

Dither frequency of the displacement control valve in Hz.

### DAMPL:Q (Dither Amplitude)

Dither amplitude of the displacement control valve in 0,01 % of the current.

 The Dither can be set with Dither amplitude and Dither frequency.

 **The below mentioned value for Dither amplitude and frequency should not be changed when using a PVCMD1FB\*\*\* or a PVCM\*PV\*\*!**

DFREQ:Q = 120

DAMPL:Q = 400

### DFREQ:P (Dither Frequency)

Dither frequency of the pressure control valve in Hz.

### DAMPL:P (Dither Amplitude)

Dither amplitude of the pressure control valve in 0,01 % of the current.

 The Dither can be set with Dither amplitude and Dither frequency.

 **The below mentioned value for Dither amplitude and frequency should not be changed when using a PVACRE\*\*\*K\*\*!**

DFREQ:p = 60

DFREQ:p = 400

### PWM:Q (PWM Frequency)

PWM frequency of the displacement control valve in Hz.

### PPWM:Q (P gain)

P gain of the solenoids control (displacement control valve).

### IPWM:Q (I gain)

I gain of the solenoids control (displacement control valve).

### PWM:P (PWM Frequency)

PWM frequency of the pressure valve solenoid in Hz.

### PPWM:P (P gain)

P gain of the solenoids control (pressure control valve).

### IPWM:P (I gain)

I gain of the solenoids control (pressure control valve).

### ATTENTION!

 **PPWM and IPWM parameter are influencing the Dither settings. This parameter should not be changed after the Dither optimization.**

 **The solenoid control parameter are optimized for the usage of PVACRE\*\*\*K\*\* as pressure valves or PVCMD1FB\*\*\* respectively PVCMD1PV\*\* as displacement valve. This parameter should not be changed if using these valves!**

### 6.4 PID Parameter Setting

Displacement and pressure control have separate control loops, whose parameters need to be set separately. The pressure control should be focused on, since the system behaviour is depending on hydraulic capacities, the way of piping to the hydraulic load and the varying hydraulic working points. The displacement control should only be tuned again in case of system instabilities.

The parameter of proportional-, integral and differential action should be adjusted in the ranges shown below. The setting for the pressure control can also be beyond these points depending on the system.

Control Type	Action	Typical Ranges		Tendency
		Minimal Value FD* / UD*	Maximal Value FD* / UD*	
Pressure	P	10	200	<b>Depending on hydraulic system!</b>
	I	150	-	
	D	0	200	
Displacement	P	50 (80)	3000 (800)	Proportional to the pump displacement.
	I	$V_g < 92 \text{ cm}^3/\text{rev.}$ → 200 (1500)	$V_g < 32 \text{ cm}^3/\text{rev.}$ → -	Only linearity errors of the displacement valve are compensated.
		$V_g \geq 92 \text{ cm}^3/\text{rev.}$ → 80 (300)	$V_g \geq 32 \text{ cm}^3/\text{rev.}$ → -	Bigger displacements can be parameterized with smaller I-gain without getting system stability into jeopardy.
D	0	1200 (600)		

#### Recommendation for the PID parameter setting: **PID Setting:**

##### Preparations:

- Set P action to small value.
- Set I action to very high value.
- Set D action to zero.

- Increase P until a acceptable command response is achieved.
- Decrease I until a acceptable error between command and actual value is achieved.
- Increase D until a acceptable dynamic and acceptable ripple is achieved in the command response.

**Typical Step Responses:**

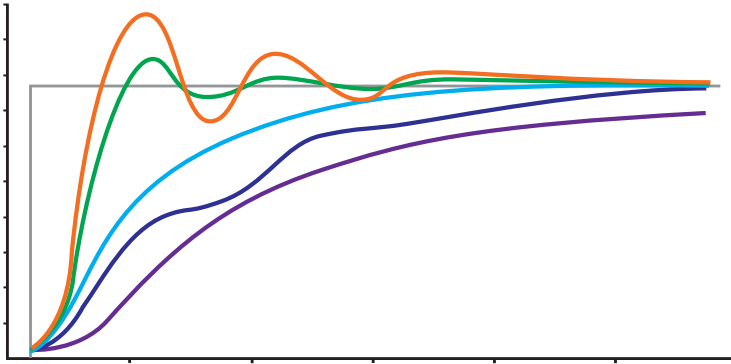

**Selected Step Responses:**

- Actual value nears only slow to the c  
ommand value:  
→ Increase P action, if this improves,  
decrease I, iterate possibly.
- Actual value nears only slow and with  
small oscillations to the command value:  
→ Increase P action, if this improves,  
decrease D action, iterate possibly.
- Actual value nears only without overshoot  
to the actual value:  
→ Increase P action to get a faster  
response in the actual value.
- Actual value nears with small overshoots  
to the command value:  
→ Optimal system behaviour  
→ If no overshoots are not allowed,  
reduce P action
- Actual value nears with fast to the  
command value but overshoots are to big  
→ Decrease P action, if this improves,  
increase I action, iterate possibly.

**6.5 Important settings and diagnosis values**

**Settings- and diagnosis values for CIP**

Size/Code	Diagnosis signal $V_{Gmax}$ [Volt <sup>-0,5</sup> ]	CIP signal $A_{max}$ [mA <sup>+0,4</sup> ]	Diagnosis signal $V_{Gmin}$ [Volt]	CIP signal $A_{max}$ [mA <sup>±0,25</sup> ]
PVXXX	10	20	0.15	4

**Settings- and diagnosis values for LVTD**

Size/Code	max. displacement [[cm <sup>3</sup> /rev.]	Diagnosis signal V <sub>G max</sub> [Volt -0,5]	LVDT signal V <sub>G max</sub> [Volt ±0,25]	Diagnosis signal V <sub>Gmin</sub> [Volt]	LVDT signal V <sub>Gmin</sub> [Volt ±0,25]
PV016	16	10.0	6.34	0.0	7.5
PV020	20		6.06		
PV023	23		5.87		
PV028	28		5.50		
PV032	32		6.40		
PV040	40		5.70		
PV046	46		5.43		
PV063	63		7.12		9.0
PV080	80		6.48		
PV092	92		6.10		
PV140	140		5.24		
PV180	180		3.83		
PV270	270		4.06		
PV360	360		4.06		

**Max. Horse power [and according horse power command**

Size/Code	@350bar @1500 rpm [kW]	Command for max. power [V]
PV016	16.4	10.0
PV020	20.9	
PV023	23.8	
PV028	29.0	
PV032	33.1	
PV040	39.8	
PV046	46.1	
PV063	62.1	
PV080	75.5	
PV092	86.9	
PV140	133.0	
PV180	168.8	
PV270	247.0	
PV360	331.2	

**Calculation example for the external command:**

A PV028 is driven with an input horse power of 15.0 kW. Maximum horse power is 29.0 kW (PL:PL = 290). The voltage command input according to this input horse power is 10.0 V as shown in the table left side.

To adjust a horse power limit of 15.0 kW a command voltage of.

**15.0 kW / 29.0 kW x 10.0 V = 5.2 V**

need to be set at PIN 29.

**7.1 Connecting diagram for proportional displacement control; Code ...FDV**

➔ **Base parameter sets for FDV are available with module firmware PQDXXA-Z10-r03 and higher.** (cable details see page 13 to 15)

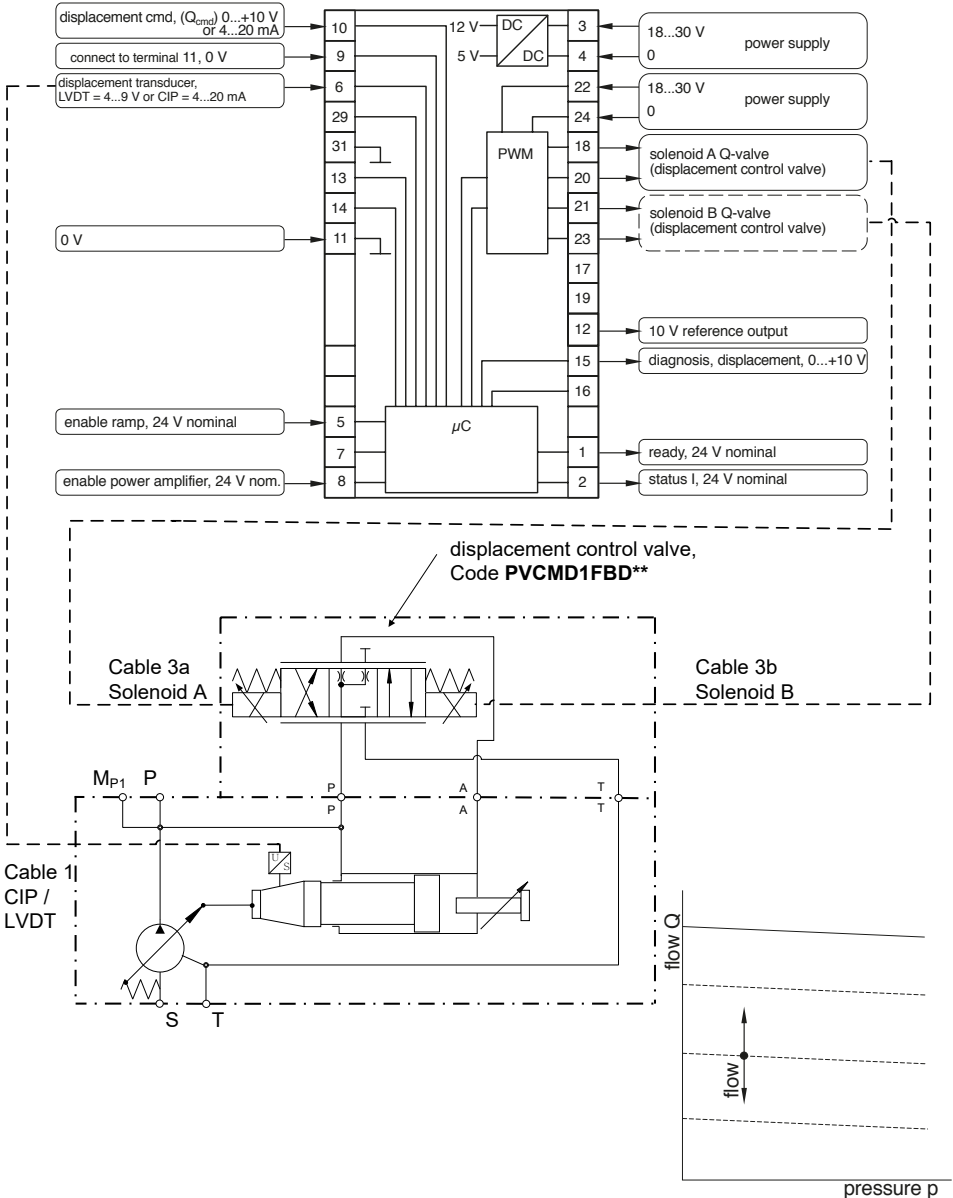

**7.2 Connecting diagram for proportional displacement control; Code ...FPV**

(cable details see page 13 to 15)

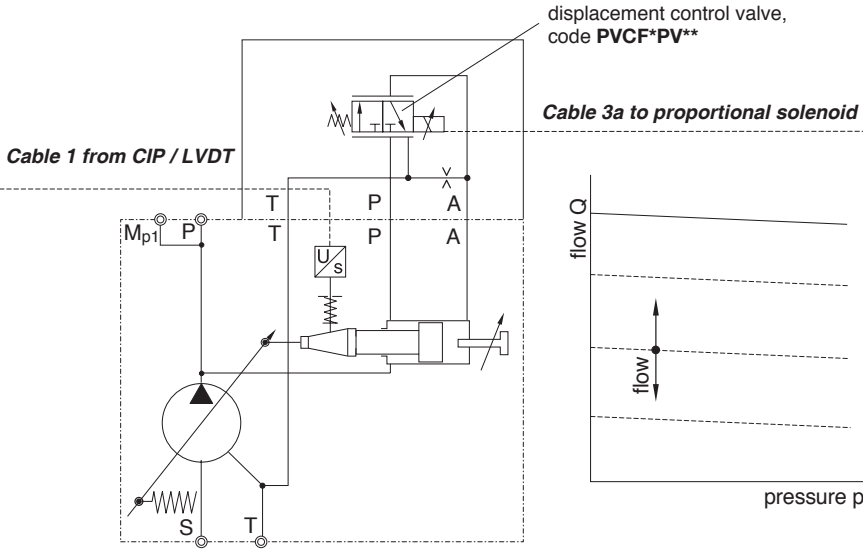
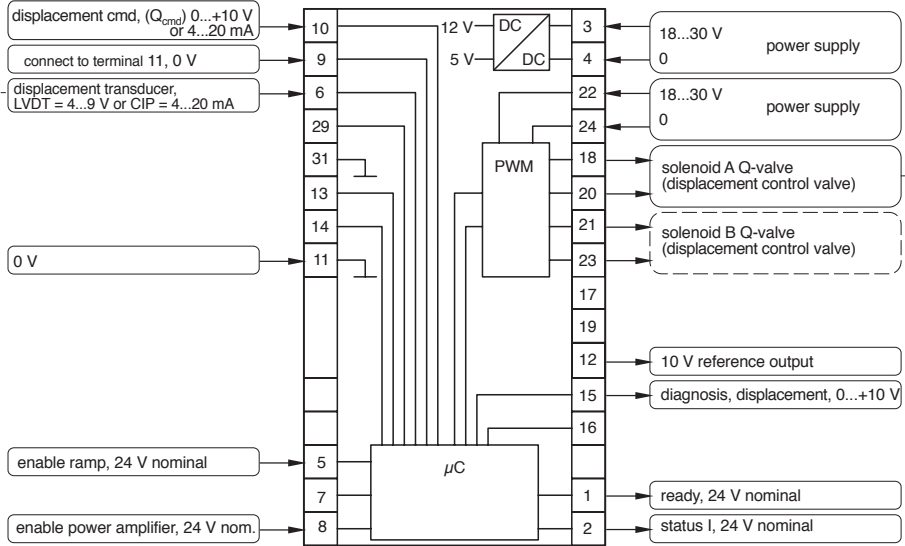

**8.1 Connecting diagram for p/Q-control; Codes ..UDR, ...UDK, ...UDM, ...UDS, ...UDQ, ... UDP und ...UDF**

👉 **Base parameter sets for UD\* are available with module firmware PQDXXA-Z10-r03 and higher. (cable details see page 13 to 15)**

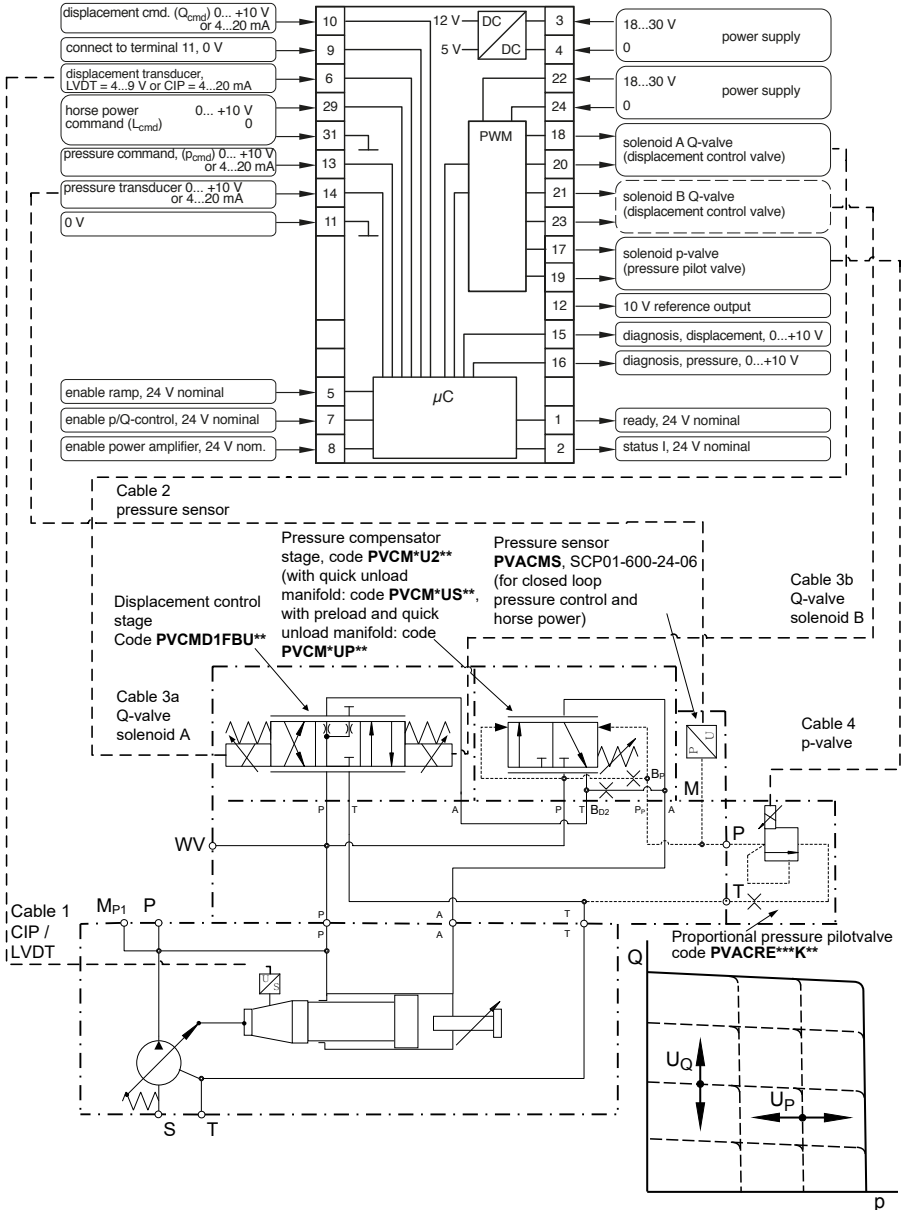



**8.2 Connecting diagram for p/Q-control; Codes ..UPR, ...UPK, ...UPM, ...UPS, ...UPQ, ...UPP and ...UPF (cable details see page 13 to 15)**

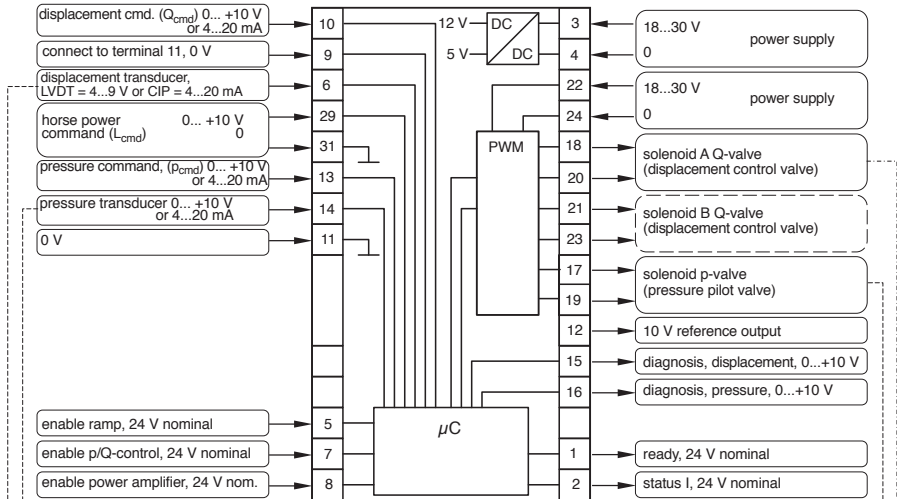

**Cable 4 from pressure sensor**

**Cable 3a to displacement Control stage solenoid**

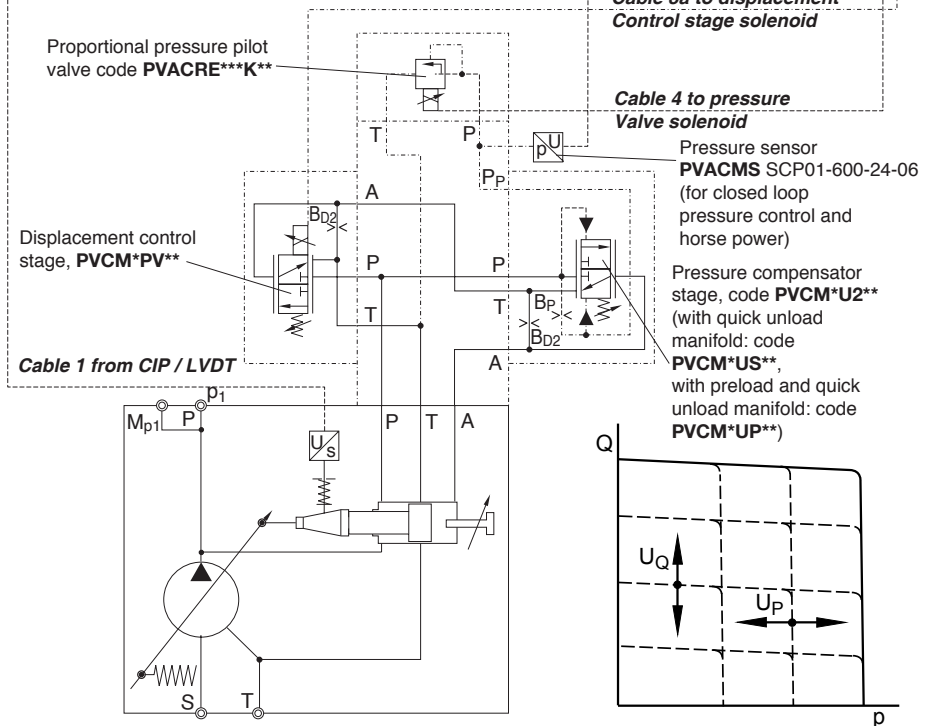

**Cable 1 from CIP / LVDT**

**Cable 4 to pressure Valve solenoid**

Pressure sensor **PVACMS SCP01-600-24-06** (for closed loop pressure control and horse power)

Pressure compensator stage, code **PVCM\*U2\*\*** (with quick unload manifold: code **PVCM\*US\*\***, with preload and quick unload manifold: code **PVCM\*UP\*\***)

## 9. Trouble shooting guide

<b>Pump delivers no output flow Drive motor does not turn</b>	
reason	Motor is not connected correctly or one of the three phases has failed. Motor does not turn smoothly when pump is disconnected from pump.
solution	<i>Check motor connections, check electrical power supply.</i>
reason	Pump is mechanically blocked. Motor turns smoothly when disconnected from pump.
solution	<i>Send pump for service to factory.</i>
<b>Drive motor only turns at slow speed</b>	
reason	Motor is not selected properly. Installed motor has not enough torque.
solution	<i>Start pump at unloaded system. Use motor with more horse power.</i>
reason	Pump is hydraulically blocked. No function of compensator, no pressure relief valve; Pump stops after a few turns.
solution	<i>Check function of pump compensator (see below). Start pump at unloaded system.</i>
<b>Drive motor turns, pump does not turn</b>	
reason	Coupling is not or not correctly mounted.
solution	<i>Check coupling assembly and correct it.</i>
<b>Drive motor turns and pump turns</b>	
reason	Wrong direction of rotation.
solution	<i>Change direction of motor rotation.</i>
reason	Fluid reservoir empty or not filled to level, suction line ends above fluid level.
solution	<i>Fill reservoir to required level, if necessary increase suction pipe length.</i>
reason	Suction line is blocked. E.g. by plugs, cleaning tissues, plastic-plugs. Ball valve in the suction line closed. Suction filter blocked.
solution	<i>Check suction line for free flow. Open valves in suction line. Valves should be equipped with electrical indicator. Check suction filter.</i>
reason	Suction line not gas tight, pump gets air into suction port.
solution	<i>Seal suction line against air ingress.</i>
reason	Pressure line / system is not able to bleed air out.
solution	<i>Unload pressure port, unload system before start, bleed air from pressure line.</i>
<b>Pump does not build up pressure, but delivers full flow at low pressure</b>	
reason	Standard pressure compensator is set to minimum pressure.
solution	<i>Adjust compensator setting to desired pressure.</i>
reason	No pressure pilot valve connected to port P <sub>R</sub> .
solution	<i>Install suitable pressure pilot valve and adjust it to the desired setting.</i>
reason	Multiple pressure pilot selector valve is not energized; Pump works in stand-by.
solution	<i>Energize selector valve solenoid.</i>
reason	Differential pressure at compensator is adjusted properly (too low).
solution	<i>Check differential pressure adjustment and correct it as described above.</i>

**Trouble shooting guide**

<b>Pump does not build up pressure, but delivers full flow at low pressure</b>	
reason solution	Horse power compensator setting changed. <i>Check setting of horse power compensator and correct it, if required.</i>
reason solution	Proportional displacement control is not connected as required. <i>Check wiring; connect according to installation manual for electronic module.</i>
reason solution	Displacement transducer (LVDT) adjustment changed. <i>Correct zero setting at displacement transducer.</i>
reason solution	Electronic module has no supply power. <i>Make sure module is powered with 22 – 36 V DC.</i>
reason solution	Cylinder block lifts from valve plate due to excessive wear. <i>Send pump to factory for service.</i>
<b>Pump does not compensate</b>	
reason solution	No pressure pilot valve connected to compensator or valve is blocked. <i>Connect pressure pilot valve to compensator, make sure valve opens as required.</i>
reason solution	No or too low pressure at pump outlet port. <i>Pump outlet pressure must be at least 15 bar, because otherwise the bias spring in the pump cannot be compressed.</i>
<b>Pump does not upstroke, sticks at zero displacement.</b>	
reason solution	Compensator is blocked due to contamination. <i>Clean hydraulic fluid, clean compensator valve.</i>
reason solution	Cable to LVDT or proportional solenoid is interrupted <i>Check wiring and make sure cable is ok. Replace if necessary.</i>
<b>Compensator is unstable</b>	
reason solution	Compensator spool is sticking due to contamination of hydraulic fluid. <i>Clean hydraulic system, clean compensator valve.</i>
reason solution	Compensator differential pressure changed (too low or too high) <i>Adjust compensator differential pressure to required setting.</i>
reason solution	Wrong pilot orifice or pressure pilot valve improperly selected. <i>Select pilot orifice and pressure pilot valve as recommended.</i>
reason solution	Dynamic critical system, e.g.: pressure compensator combined with pressure reducing valve. <i>use remote pressure compensator instead of standard pressure compensator.</i>

## Position notification regarding Machinery Directive 2006/42/EC:

Products made by the Pump & Motor Division Europe (PMDE) of Parker Hannifin are excluded from the scope of the machinery directive following the "Cetop" Position Paper on the implementation of the Machinery Directive 2006/42/EC in the Fluid Power Industry.

All PMDE products are designed and manufactured considering the basic as well as the proven safety principles according to:

- ISO 13849-1:2015
- SS-EN ISO 4413:2010

so that the machines in which the products are incorporated meet the essential health and safety requirements.

Confirmations for components to be proven component, e. g. for validation of hydraulic systems, can only be provided after an analysis of the specific application, as the fact to be a proven component mainly depends on the specific application.

### Dr. Hans Haas

General Manger

Pump & Motor Division Europe



## WARNING – USER RESPONSIBILITY

**FAILURE OR IMPROPER SELECTION OR IMPROPER USE OF THE PRODUCTS DESCRIBED HEREIN OR RELATED ITEMS CAN CAUSE DEATH, PERSONAL INJURY AND PROPERTY DAMAGE.**

This document and other information from Parker-Hannifin Corporation, its subsidiaries and authorized distributors provide product or system options for further investigation by users having technical expertise.

The user, through its own analysis and testing, is solely responsible for making the final selection of the system and components and assuring that all performance, endurance, maintenance, safety and warning requirements of the application are met. The user must analyze all aspects of the application, follow applicable industry standards, and follow the information concerning the product in the current product catalogue and in any other materials provided from Parker or its subsidiaries or authorized distributors.

To the extent that Parker or its subsidiaries or authorized distributors provide component or system options based upon data or specifications provided by the user, the user is responsible for determining that such data and specifications are suitable and sufficient for all applications and reasonably foreseeable uses of the components or systems.

## Offer of Sale

Please contact your Parker representation for a detailed "Offer of Sale".

**For additional information, spare parts or service requirements please contact:**

### Parker Hannifin Manufacturing Germany GmbH & Co KG

Pump & Motor Division Europe

Neefestraße 96

09116 Chemnitz, Germany

Tel: +49 (0)371 - 3937 - 0

Fax: +49 (0)371 - 3937 - 488

Email: pmde-pqd-support@parker.com

parker.com/pmde

MSG30-3255-INST/UK



© Copyright 2021  
All rights reserved